

CUSTOM ORDER SPECIFICATIONS

Table 1 Manufacturable Range

	Current Signal	Voltage Signal
Output Range	0~24mA DC	-10~+10V DC
Span	1~24mA DC	10mV~20V DC
Zero Elevation	0~200%	-100~+200%

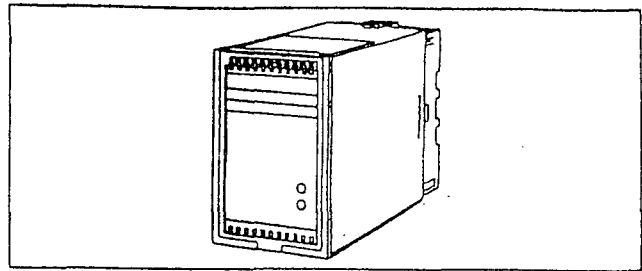

TERMINAL ARRANGEMENT

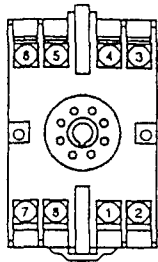

1	OUTPUT (+)
2	OUTPUT (-)
3	INPUT (+)
4	INPUT (-)
5	INPUT mVcheck(-)
6	GND (G)
7	SUPPLY (L+)
8	SUPPLY (N-)

BLOCK DIAGRAM

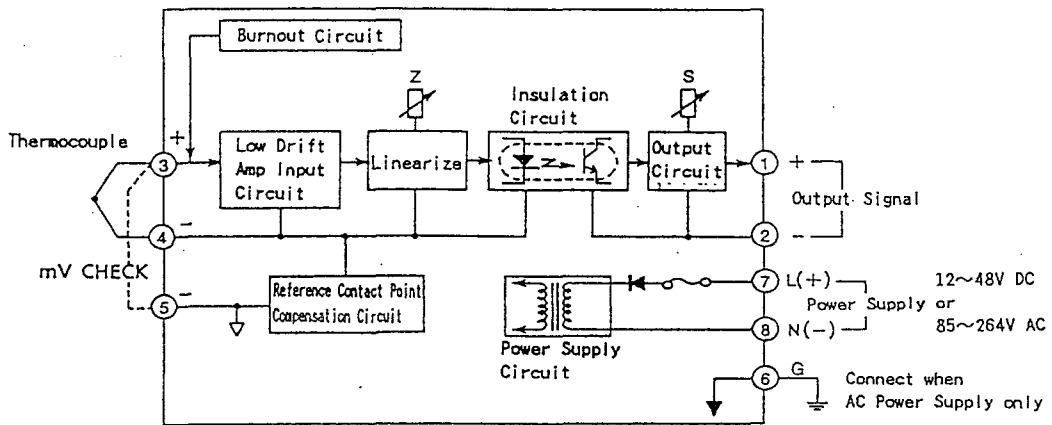

EXTERNAL DIMENSION

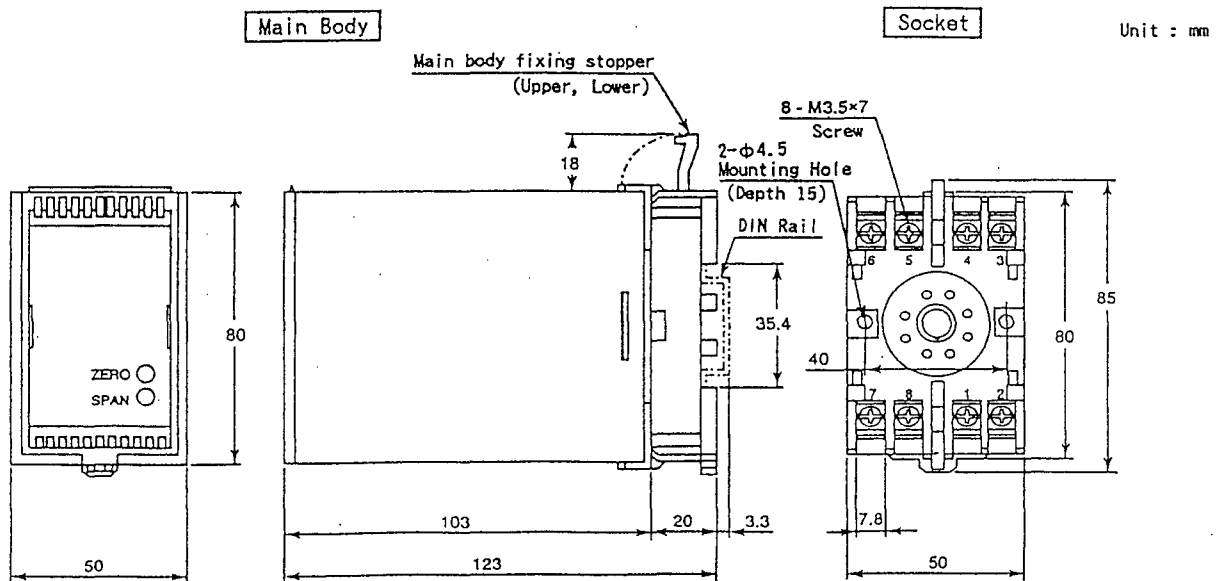

Subject to change without notice for grade up quality and performance